

SECTION B-B

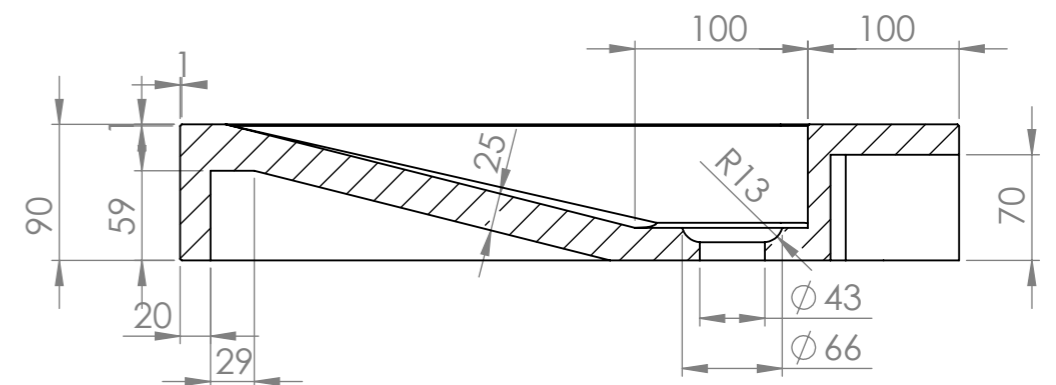
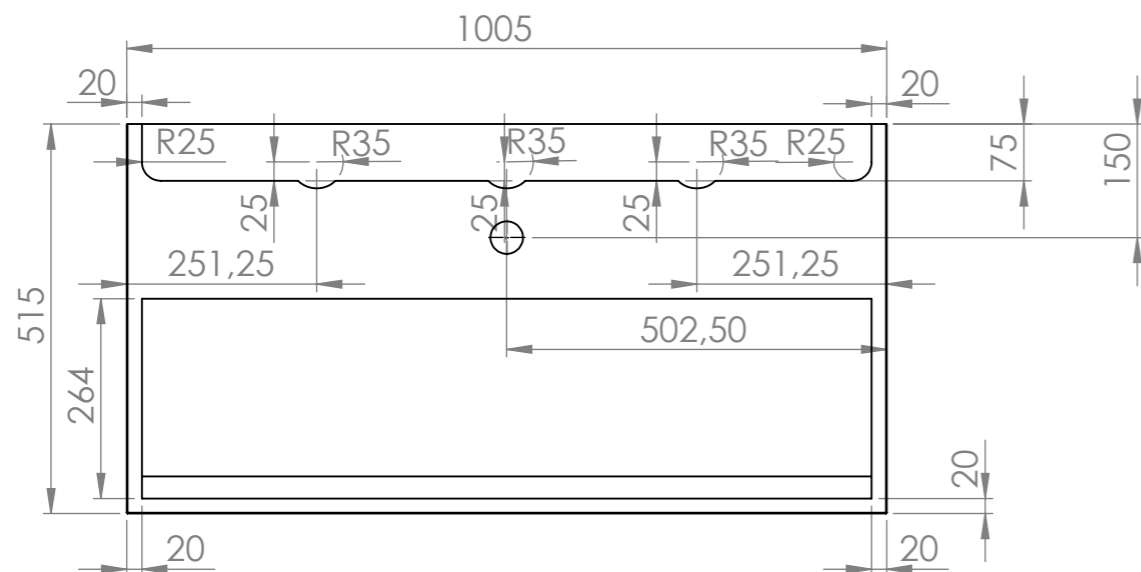

SECTION A-A
SCALE 1 : 5

UNLESS OTHERWISE SPECIFIED: DIMENSIONS ARE IN MILLIMETERS SURFACE FINISH: TOLERANCES: LINEAR: ANGULAR:	FINISH:	DEBUR AND BREAK SHARP EDGES	DO NOT SCALE DRAWING	REVISION
			TITLE: Palermo	
	NAME			
DRAWN	E. Anninga			
APPV'D	R. Straten			
MFG				
Q.A		MATERIAL:	DWG NO.	A3
		WEIGHT: 58.4 kg (2.9 p)	SCALE: 1: 8	SHEET 1 OF 1