





## ORLEANS - LED-Spiegel



-  IP44
-  Niedriger Verbrauch. Led Samsung.
-  Norm CE
-  3 Jahre Garantie
-  Spiegel mit Hintergrundbeleuchtung
-  Arbeitsbeleuchtung
-  Sensor ein/aus

### Technische Eigenschaften

	600	700	800	900	1000	1200	1400
Kelvin	5700 (cool light)						
Lúmenes	415	480	560	580	610	720	910
Wattios	10+22	12+22	15+32	20+36			
Korrosionsschutz	Si						
Energieeffizienz	F						
Glasdicke	4 mm						
CRI	>90						
Lebensdauer	3000 h						

### Abmessungen

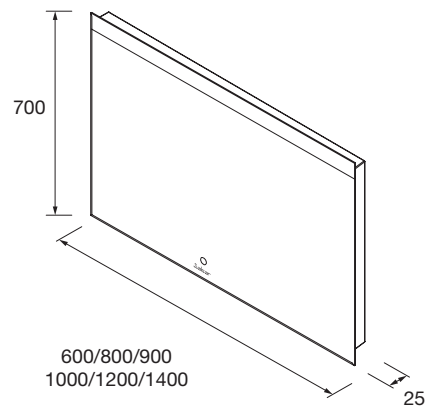

### Abmessungen und Verpackungsgewicht

	600	700	800	900	1000	1200	1400
Länge (mm)	685	785	885	985	1085	1285	1485
Tiefe (mm)	75						
Höhe (mm)	765						
Nettogewicht (kg)	5,7	6	6,5	7,2	8,2	10,2	12,2
Bruttogewicht (kg)	6,5	7	7,3	8,3	9,1	11	13

### Installationsmessungen

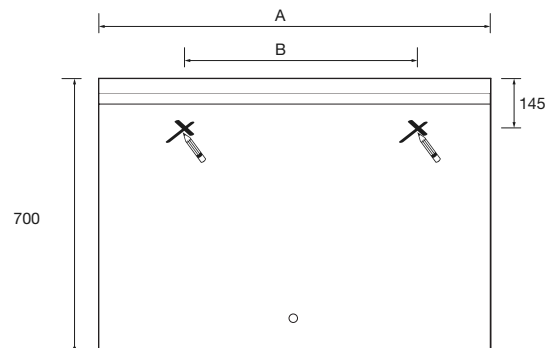

- A=604 → B=300
- A=704 → B=400
- A=804 → B=500
- A=904 → B=500
- A=1004 → B=500
- A=1204 → B=500
- A=1404 → B=500